

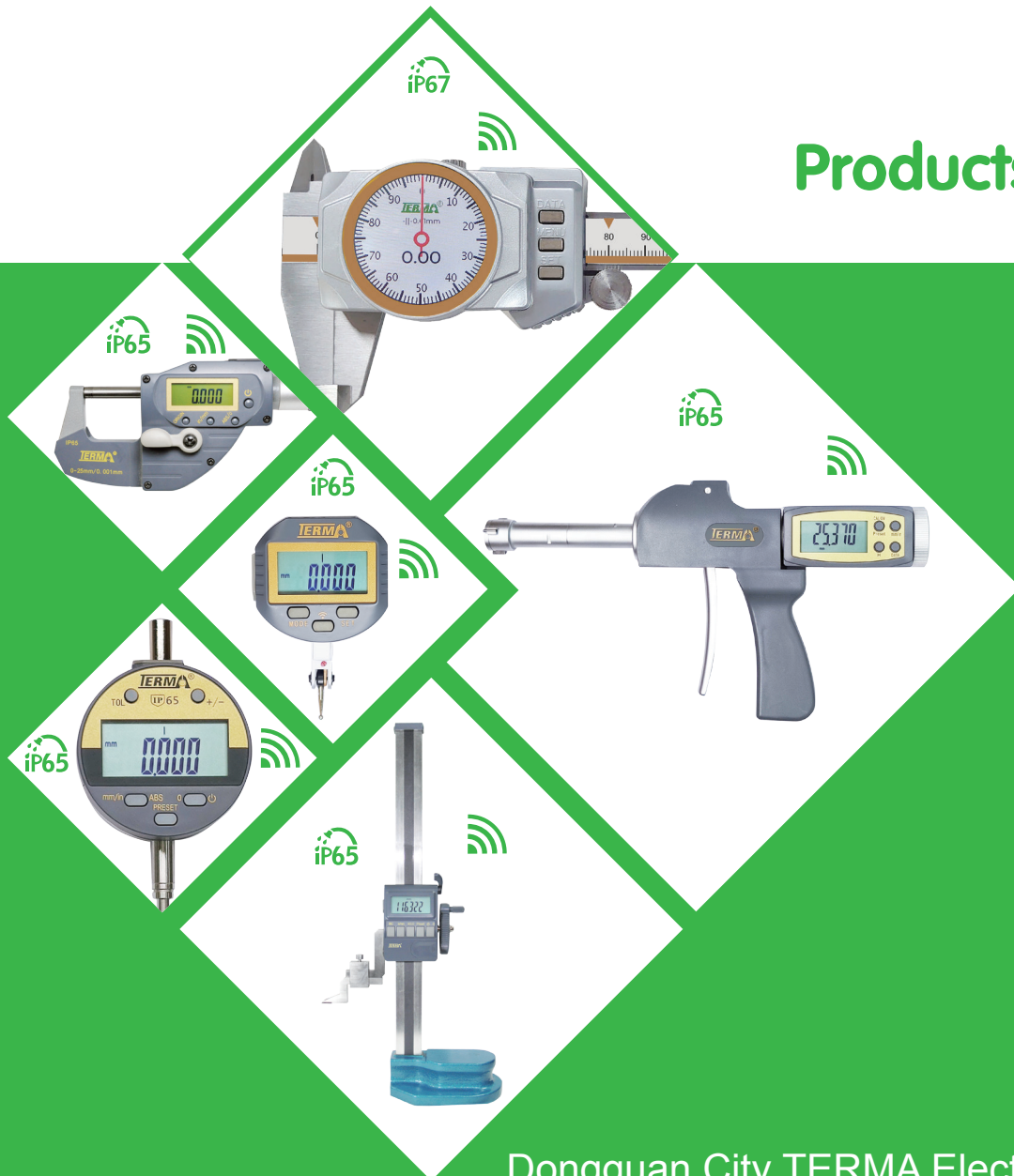

特马[®]量具

Terma Tools

2024 Products Profile



► Profile

Dongguan City TERMA Electronics Co., Ltd is a high-tech enterprise specializing in the research and development, design, production, sales and service of precision measuring tools. The company fully implements the ISO9001:2015 management system, national standard, DIN quality standards, and other international standards, has strong guarantee in product development, production process, production management, quality assurance and after-sales service, etc.

The company has always adhered to the quality policy of improving service, ensuring quality and satisfying customers. With advanced technology, excellent products, stable quality and comprehensive service as its aim. Besides domestic sales, the products are also exported to Europe, America, Southeast Asia and other countries and regions.

We make unremitting efforts to realize the goal of standardized management and stable product quality, and we look forward to your cooperation and support!



Spindle Thread Grinding



Caliper Mechanism Grinding



Hi-Speed CNC



High Precision Grinding Machine



IC Bonding



Micro Indicator Inspection

Ability:

- 1.40000 set per month for caliper;
- 2.30000 set per month for micrometer;
- 3.10000 set for digital indicator and digital micro indicator;
- 4.20000 set per month for other measuring tools(digital protractor、digital compass、digital level and so on)
- 5.IC design and bonding

Contents

SPC (Data Transmission)	* * * * *	1-1
Caliper	* * * * *	2-5
Height Gage	* * * * *	6-6
Indicator & Micro Indicator	* * * * *	6-7
Three Point Internal Micrometer	* * * * *	7-8
Micrometer	* * * * *	8-11
Digital Thickness Gage	* * * * *	11-11
Digital Protractor	* * * * *	12-12
Digital Level	* * * * *	12-12
Others	* * * * *	12-12

Test Report

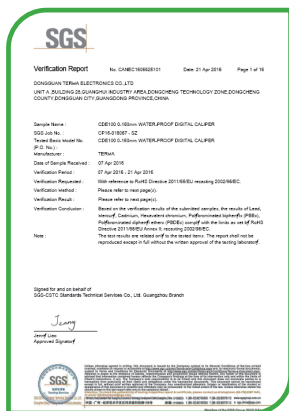

Rohs Report



CE Report

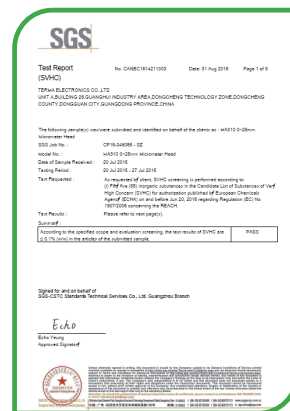

Reach Report



IP67 Report





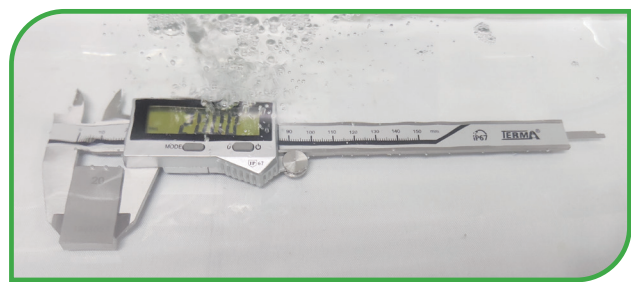



IP65 Testing









IP67 Testing

▶ SPC (Data Transmission)

Wireless Data Transmission Device with 8 channels

 <p>Transmitting device: SPC-W1-RS (5PIN/USB-ITN-F)</p>	 <p>Transmitting device: SPC-W1-RS1 (Micro usb)</p>	 <p>Transmitting device: SPC-W1-RS2 (5PIN/USB-ITN-F)</p>	 <p>Transmitting device: SPC-W1-RS3 (Micro usb)</p>
 <p>Transmitting device: SPC-W1-RS4 (USB-ITN-A)</p>	 <p>Transmitting device: SPC-W1-RS5 (USB-ITN-B)</p>	 <p>Receiver: SPC-W1-RM</p>	

External Bluetooth Transmission Device

 <p>Transmitting device: SPC-W2-RS (5PIN/USB-ITN-F)</p>	 <p>Transmitting device: SPC-W2-RS1 (Micro usb)</p>	 <p>Transmitting device: SPC-W2-RS2 (5PIN/USB-ITN-F)</p>	 <p>Transmitting device: SPC-W2-RS3 (Micro usb)</p>
 <p>Transmitting device: SPC-W2-RS4 (USB-ITN-A)</p>	 <p>Transmitting device: SPC-W2-RS5 (USB-ITN-B)</p>	 <p>Foot switch: TFS-201</p>	

Wire Data Output Device

 <p>The plug can be chose C-01, C-02, and C-03</p> <p>SPC-A</p> <p>SPC Cable for incremental measuring tools</p>	 <p>Foot switch: TFS-201</p>	 <p>The plug can be chose C-01, C-03, and C-04, C-05, C-06</p> <p>SPC-B</p> <p>SPC Cable for absolute measuring tools</p>
---	---	---

 <p>C-01: Micro 5pin plug</p>	 <p>C-02: special plug to incremental caliper</p>	 <p>C-03: special plug (5Pin/USB-ITN-F)</p>	 <p>C-04: special plug with button (5Pin/USB-ITN-C)</p>	 <p>C-05: water proof plug with key (USB-ITN-A)</p>	 <p>C-06: water proof 90° plug with key (USB-ITN-B)</p>
--	--	--	--	---	--

► Caliper



CDE210/CDE210W-0.01
0-150mm/0-200mm/0-300mm

IP67 Water-Proof Color Screen Digital Caliper with Inductive Measuring System

First LED color screen in the world.
6 kinds of resolution display.
Backlight display with three kinds of brightness and six kinds of power off time.
Tolerance reminder.
Magnetic charging.
Built-in bluetooth.



IP67 Water-Proof Digital Caliper with Inductive Measuring System

CDE110/CDE110W-0.01
CDE110M/CDE110MW-0.001
0-150mm/0-200mm/0-300mm

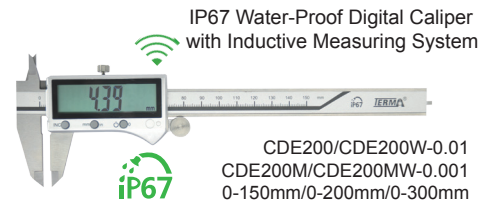

IP67 Water-Proof Digital Caliper with Inductive Measuring System

CDE200/CDE200W-0.01
CDE200M/CDE200MW-0.001
0-150mm/0-200mm/0-300mm

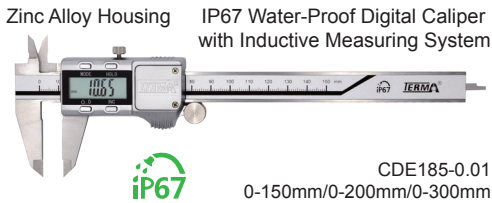

Zinc Alloy Housing IP67 Water-Proof Digital Caliper with Inductive Measuring System

CDE185-0.01
0-150mm/0-200mm/0-300mm



IP67 Water-Proof Digital Caliper with Inductive Measuring System

CDE100-0.01
0-150mm/0-200mm/0-300mm



IP65 Water-Proof Digital Caliper

CDA100-0.005
0-150mm/0-200mm/0-300mm

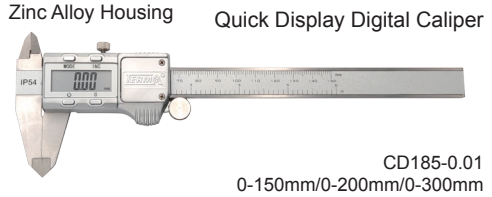

Zinc Alloy Housing Quick Display Digital Caliper

CD185-0.01
0-150mm/0-200mm/0-300mm



High Resolution Digital Caliper

CD730-0.005
0-150mm/0-200mm/0-300mm



Quick Display Digital Caliper

CD510-0.01
0-150mm/0-200mm/0-300mm

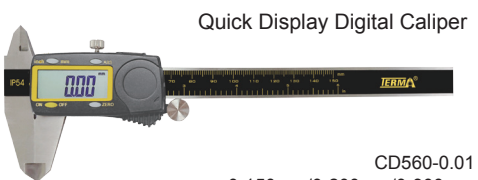

Quick Display Digital Caliper

CD560-0.01
0-150mm/0-200mm/0-300mm

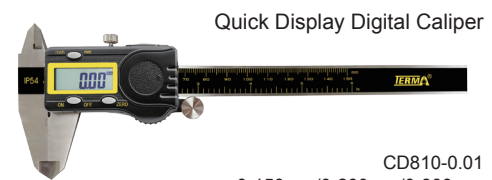

Quick Display Digital Caliper

CD810-0.01
0-150mm/0-200mm/0-300mm

► Caliper

Quick Display Digital Caliper



CD710-0.01
0-150mm/0-200mm/0-300mm

Dial Caliper



CB210-0.02
0-150mm/0-200mm/0-300mm

Vernier Caliper

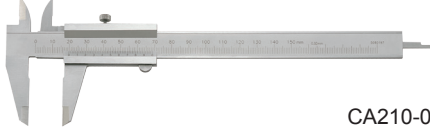

CA210-0.02
0-150mm/0-200mm/0-300mm

IP67 Water-Proof Digital Depth Caliper with double Hook



SDE110/SDE110W-A-0.01
0-150mm/0-200mm/0-300mm

IP67 Water-Proof Digital Depth Caliper with single Hook



SDE110/SDE110W-B-0.01
0-150mm/0-200mm/0-300mm

IP67 Water-Proof Digital Depth Caliper with Flat Head



SDE110/SDE110W-C-0.01
0-150mm/0-200mm/0-300mm

IP67 Water-Proof Digital Depth Caliper with Replaceable Probe



SDE110/SDE110W-D-0.01
0-150mm/0-200mm/0-300mm

Quick Display Digital Depth Caliper with double Hook

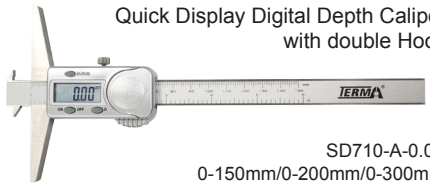

SD710-A-0.01
0-150mm/0-200mm/0-300mm

Quick Display Digital Depth Caliper with single Hook

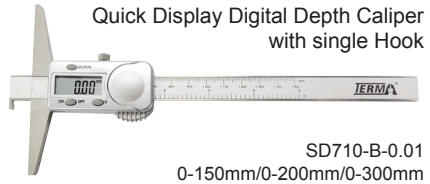

SD710-B-0.01
0-150mm/0-200mm/0-300mm

Quick Display Digital Depth Caliper with Flat Head

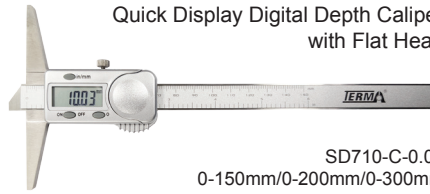

SD710-C-0.01
0-150mm/0-200mm/0-300mm

Quick Display Digital Depth Caliper with Replaceable Probe

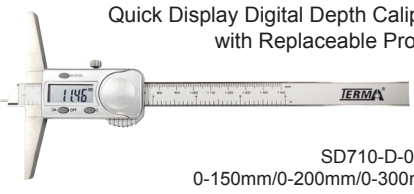

SD710-D-0.01
0-150mm/0-200mm/0-300mm

► Caliper

IP67 Water-Proof Digital Caliper with Thick Pipe Wall



YDE200A/YDA200WA-0.01
0-150mm/0-200mm/0-300mm

IP67 Water-Proof Digital Caliper with Flat Head External Groove



YDE200B/YDE200WB-0.01
0-150mm/0-200mm/0-300mm

IP67 Water-Proof Digital Caliper with Flat Head Cutter Groove



YDE200C/YDE200WC-0.01
0-150mm/0-200mm/0-300mm

IP67 Water-Proof Digital Caliper with Flat Head Internal Groove



YDE200D/YDE200WD-0.01
0-150mm/0-200mm/0-300mm

IP67 Water-Proof Digital Caliper with Replaceable Probe and Internal & External Groove(with Top Claw)



YDE200E/YDE200WE-0.01
0-150mm/0-200mm/0-300mm

IP67 Water-Proof Digital Caliper with Replaceable Probe and Internal & External Groove(without Top Claw)



YDE200F/YDE200WF-0.01
0-150mm/0-200mm/0-300mm

IP67 Water-Proof Digital Caliper with Thin Sharp Claw



YDE200G/YDE200WG-0.01
0-150mm/0-200mm/0-300mm

IP67 Water-Proof Digital Caliper with Center distance



YDE200H/YDE200WH-0.01
0-150mm/0-200mm/0-300mm

IP65 Water-Proof Digital Caliper with Thick Pipe Wall

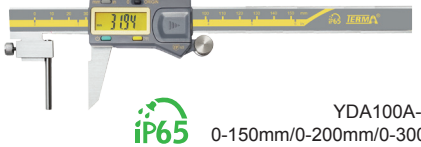

YDA100A-0.01
0-150mm/0-200mm/0-300mm

IP65 Water-Proof Digital Caliper with Flat Head External Groove



YDA100B-0.01
0-150mm/0-200mm/0-300mm

IP65 Water-Proof Digital Caliper with Flat Head Cutter Groove



YDA100C-0.01
0-150mm/0-200mm/0-300mm

IP65 Water-Proof Digital Caliper with Flat Head Internal Groove

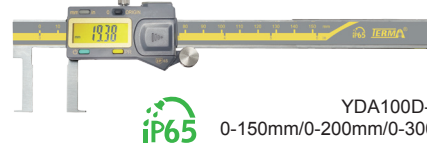

YDA100D-0.01
0-150mm/0-200mm/0-300mm

► Caliper

IP65 Water-Proof Digital Caliper with Replaceable Probe and Internal & External Groove(with Top Claw)



YDA100E-0.01
0-150mm/0-200mm/0-300mm

IP65 Water-Proof Digital Caliper with Replaceable Probe and Internal & External Groove(without Top Claw)



YDA100F-0.01
0-150mm/0-200mm/0-300mm

IP65 Water-Proof Digital Caliper with Thin Sharp Claw

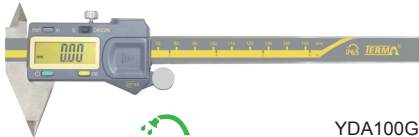

YDA100G-0.01
0-150mm/0-200mm/0-300mm

IP65 Water-Proof Digital Caliper with Center distance

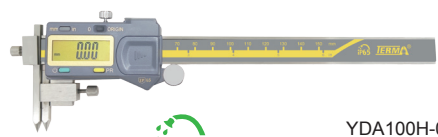

YDA100H-0.01
0-150mm/0-200mm/0-300mm

Heavy Duty Mono-Block Vernier Caliper

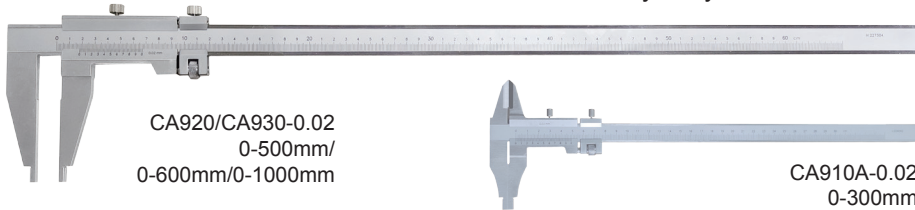

CA920/CA930-0.02
0-500mm/
0-600mm/0-1000mm

CA910A-0.02
0-300mm



IP65 Water-Proof Carbon Fiber Digital Caliper with Inductive Measuring System



CDE932/CDE932W-0.01
0-600mm/0-1000mm/
0-1500mm/0-2000mm/
0-2500mm/0-3000mm

Claw length:
138mm/150mm/200mm/300mm

High Strength! Super Light! 3 M Long!

IP65 Water-Proof Heavy Duty Digital Caliper with Inductive Measuring System

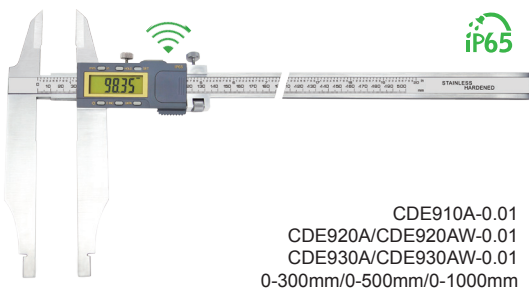

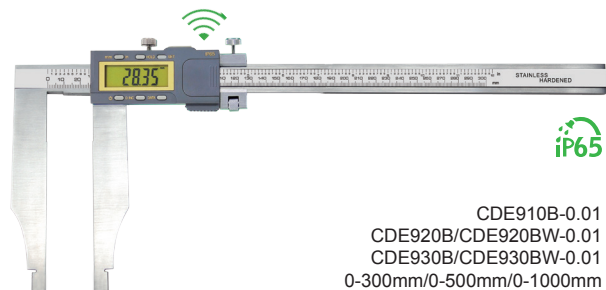

CDE910A-0.01
CDE920A/CDE920AW-0.01
CDE930A/CDE930AW-0.01
0-300mm/0-500mm/0-1000mm



CDE910B-0.01
CDE920B/CDE920BW-0.01
CDE930B/CDE930BW-0.01
0-300mm/0-500mm/0-1000mm

► Height Gage

	<p>IP65 Water-Proof Digital Height Gage with Inductive Measuring System</p> <p>HDE650/HDE650W-0.01 HDE650M/HDE650MW-0.001 0-300mm/0-460mm/0-600mm</p>		<p>Double Column Digital Height Gage</p> <p>HD220/HD220W-0.01 HD220M/HD220MW-0.001 0-300mm/0-600mm</p>		<p>Digital Height Gage with Absolute Capacitive System</p> <p>HDA620-0.01 0-150mm/ 0-200mm/ 0-300mm/ 0-460mm/ 0-600mm</p>
---	---	---	--	---	---

► Indicator



IDE111M/IDE111MW-0.001
IDE111N/IDE111NW-0.01
0-12.7mm/0-25.4mm/
0-50.8mm/0-101.6mm

IP65

IP65 Water-Proof Digital Indicator with Inductive Measuring System



IDA910/IDA910W-0.001
IDA910N/IDA910NW-0.01
0-12.7mm/0-25.4mm/
0-50.8mm

Digital Micro Indicator with Absolute Capacitive System



IDE120M/IDE120MW-0.001
0-0.2mm
IDE120/IDE120W-0.001
0-0.8mm

IP65

IP65 Water-Proof Digital Lever Indicator with Inductive Measuring System



Digital Indicator

ID220-0.01
0-12.7mm/0-25.4mm



Dial Indicator

IB210M-0.001
0-1mm
IB210N-0.01
0-10mm



Dial Lever Indicator

IB220M-0.002
0-0.2mm
IB220N-0.01
0-0.8mm



Digital Micro Indicator with Absolute Capacitive System

IDA920N-0.01
0-12.7mm

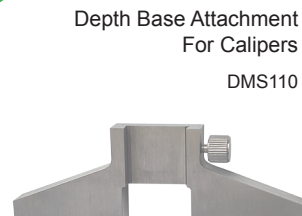

Depth Base Attachment For Calipers

DMS110



Depth Measuring Base

DMS210
64mm/101.6mm/
127mm/200mm

► Indicator

Absolute Linear Probe

IDA950LM-0.001
0-12.7mm/0-25.4mm/
0-50.8mm/0-101.6mm



IP65

Digital Indicator for Outside or Inside Radius Measurement



RDE111-0.001
0-1000mm/0-3000mm

► Three Point Internal Micrometer

Gun-Type Digital Three Point Internal Micrometer



MDA750H/MDA750HW-0.001
6-8mm/8-10mm/10-12mm/
12-16mm/16-20mm/20-25mm/
25-30mm/30-40mm/40-50mm/
50-63mm/62-75mm/75-88mm/
87-100mm/100-125mm/125-150mm/
150-175mm/175-200mm/200-225mm/
225-250mm/250-275mm/275-300mm/
300-325mm/325-350mm

Grip-Type Digital Three Point Internal Micrometer



MDA760H/MDA760HW-0.001
6-8mm/8-10mm/10-12mm/
12-16mm/16-20mm/20-25mm/
25-30mm/30-40mm/40-50mm/
50-63mm/62-75mm/75-88mm/
87-100mm/

Digital Three Point Internal Micrometer



MD732H/MD732HW-0.001
6-8mm/8-10mm/10-12mm/
12-16mm/16-20mm/20-25mm/
25-30mm/30-40mm/40-50mm/
50-63mm/62-75mm/75-88mm/
87-100mm/100-125mm/125-150mm/
150-175mm/175-200mm/200-225mm/
225-250mm/250-275mm/275-300mm/
300-325mm/325-350mm

Digital Three Point Internal Micrometer



MD730H/MD730HW-0.001
6-8mm/8-10mm/10-12mm/
12-16mm/16-20mm/20-25mm/
25-30mm/30-40mm/40-50mm/
50-63mm/62-75mm/75-88mm/
87-100mm/100-125mm/125-150mm/
150-175mm/175-200mm/200-225mm/
225-250mm/250-275mm/275-300mm/
300-325mm/325-350mm

► Three Point Internal Micrometer

Three Point Internal Micrometer

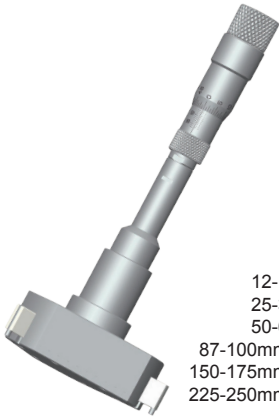

MA250H-0.001
 6-8mm/8-10mm/10-12mm/
 12-16mm/16-20mm/20-25mm/
 25-30mm/30-40mm/40-50mm/
 50-63mm/62-75mm/75-88mm/
 87-100mm/100-125mm/125-150mm/
 150-175mm/175-200mm/200-225mm/
 225-250mm/250-275mm/275-300mm/
 300-325mm/325-350mm

Digital Bore Gage set
 with Absolute Capacitive System



BGA910M/BGA910MW-0.001
 18-35mm/35-50mm/50-160mm/
 160-250mm/250-450mm

► Micrometer



Water-Proof Digital Micrometer
 with Inductive Measuring System

MDE310/MDE310W-0.001
 0-25mm/25-50mm/
 50-75mm/75-100mm



Digital micrometer

MD310-0.001
 0-25mm/25-50mm/
 50-75mm/75-100mm/
 100-125mm/125-150mm



Digital micrometer with absolute origin lever

MDA910/MDA910W-0.001
 0-25mm/25-50mm/
 50-75mm/75-100mm



Digital micrometer

MD730/MD730W-0.001
 0-25mm/25-50mm/
 50-75mm/75-100mm/
 100-125mm/125-150mm/
 150-175mm/175-200mm/200-225mm/
 225-250mm/250-275mm/275-300mm

Digital micrometer



MD710-0.001
 0-25mm/25-50mm/50-75mm/
 75-100mm/100-125mm/125-150mm

► Micrometer

Tube Thickness Measuring Digital Micrometer



MD730A/MD730WA-0.001
0-25mm/25-50mm/50-75mm/
75-100mm/100-125mm/125-150mm

Tube Thickness Measuring II Digital Micrometer



MD730-AII/MD730W-AII-0.001
0-25mm

Column Tube Thickness Measuring III Digital Micrometer



MD730-AIII/MD730W-AIII-0.001
0-25mm/25-50mm/50-75mm/
75-100mm/100-125mm/125-150mm

Double Point Digital Micrometer



MD730B/MD730WB-0.001
0-25mm/25-50mm/
50-75mm/75-100mm

Spline Digital Micrometer



MD730C/MD730WC-0.001
0-25mm/25-50mm/
50-75mm

Point Digital Micrometer

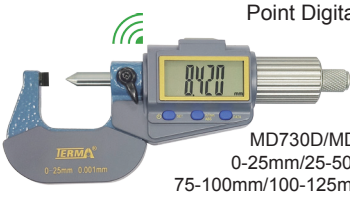

MD730D/MD730WD-0.001
0-25mm/25-50mm/50-75mm/
75-100mm/100-125mm/125-150mm

Double blade Digital Micrometer



MD730F/MD730WF-0.001
0-25mm/25-50mm/
50-75mm

Disc Digital Micrometer



MD730G/MD730WG-0.001
0-25mm/25-50mm/
50-75mm

Micrometer



MA210-0.01/MA210-0.001
0-25mm/25-50mm/50-75mm/
75-100mm/100-125mm/125-150mm/

Micrometer



MA220-0.01
0-25mm/25-50mm/50-75mm/
75-100mm/100-125mm/125-150mm/
150-175mm/175-200mm/200-225mm/
225-250mm/250-275mm/275-300mm

Tube Thickness Measuring Micrometer



MA210-A-0.01
0-25mm/25-50mm/
50-75mm/75-100mm

Tube Thickness Measuring II Micrometer



MA210-AII-0.01
0-25mm

Column Tube Thickness Measuring III Micrometer



MA210-AIII-0.01
0-25mm/25-50mm/
50-75mm/75-100mm/

Point Micrometer



MA210-B-0.01
0-25mm/25-50mm/
50-75mm/75-100mm/

► Micrometer

Spline Micrometer



MA210-C-0.01
0-25mm/25-50mm/50-75mm

Double Point Micrometer



MA210-D-0.01
0-25mm/25-50mm/50-75mm

Blade Micrometer



MA210-E-0.01
0-25mm/25-50mm/50-75mm

Disc Micrometer



MA210-F-0.01
0-25mm/25-50mm/50-75mm

Digital Micrometer Head



MD320H-0.001
0-25mm/0-50mm

Digital Micrometer Head



MD710H-0.001
0-25mm/0-50mm

MDA910-A/MDA910W-A-0.001
0-100mm/0-150mm

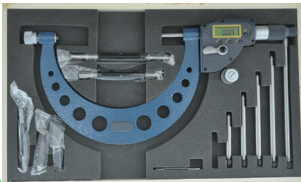

Digital Micrometers
with
Interchangeable Anvils



MDA910-B/
MDA910W-B-0.001
0-25mm/25-50mm/
50-75mm

Direct Blade Digital Micrometer



MDA910-C/
MDA910W-C-0.001
0-25mm/25-50mm/
50-75mm

Direct Spline Digital Micrometer



MDA910-D/
MDA910W-D-0.001
0-25mm/25-50mm/
50-75mm

Direct Disc Digital Micrometer

Digital Depth Micrometer

MD730DD/MD730DDW-0.001
0-150mm

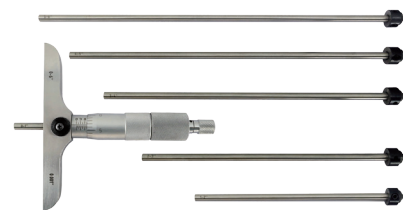

Depth Micrometer

MA230-0.001
0-150mm

Flat DMicrometer Head



MA310-0.01
0-6.5mm/0-13mm/
0-25mm/0-50mm

Flat Micrometer Head with Fix Nut



MA310C-0.01
0-6.5mm/0-13mm/
0-25mm/0-50mm

Spherical Micrometer



MA310-0.01
0-6.5mm/0-13mm/
0-25mm/0-50mm

Spherical Micrometer Head with Fix Nut



MA310C-0.01
0-6.5mm/0-13mm/
0-25mm/0-50mm

► Thickness Gage

IP65 Water-Proof
Digital External Thickness Gage
with Inductive Measuring System



TDE130A/TDE130AW-0.001
0-10mm/0-20mm/0-30mm/0-50mm/0-100mm

IP65 Water-Proof
Digital Internal Thickness Gage
with Inductive Measuring System



TDE130B/TDE130BW-0.001
5-15mm/10-30mm/30-50mm/
50-100mm/100-150mm/150-200mm

IP65 Water-Proof Digital External Thickness Gage
with Inductive Measuring System



TDE111A-0.001
TDE111AW-0.001
0-20mm/
20-40mm/
40-60mm/
60-80mm/80-100mm

IP65 Water-Proof Digital Internal Thickness Gage
with Inductive Measuring System



TDE111B-0.001
TDE111BW-0.001
15-35mm/
35-55mm/
55-75mm/
75-95mm/
95-115mm/115-135mm



TD270-0.01
0-25mm

Digital Thickness Gage



TD230A-0.01
0-25mm

Digital Thickness Gage



TD230D-0.01
0-25mm

Digital Thickness Gage



Digital External Thickness Gage

TD230E-0.1
0-150mm



Digital Internal Thickness Gage

TD230F-0.1
12.7-165mm

► Protractor



Digital Protractor
PD270D-0.05°
150mm/200mm/300mm
600mm/800mm/1000mm

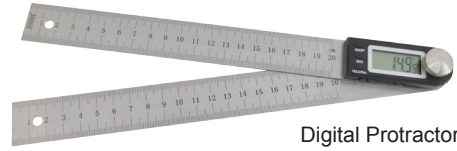

Digital Protractor
PD290-0.05°
200mm/300mm



Multifunctional
Digital Protractor

PD211-0.05°
0-360°&0-300mm

► Digital Level



LD250-0.05°
Digital Level



LD280/LD280W-0.05°
Digital Level with Charging Function

Digital Level with Laser



LD260-0.05°
150mm/200mm/600mm



LD290/LD290W-0.05°
Digital Level with Charging Function

► Others



DS220A-0.5HA/
DS220D-0.5HD
Durometer (Rubber/metal)



DT110
Wheeled Rangefinder

Digital display Z-axis tool
setting instrument



TGE280-0.001
iP65

Magnetic Stand
with Dovetail Groove



60kg(Magnetic force)
Branch Stem:
φ10x130mm
Clamp hole: φ8mm

Mechanical Universal
Magnetic Stand



80kg(Magnetic force)
Clamp hole: φ8mm

Dial Thickness Gauge
0-10mmx30mm



Inside Micrometer



5-30mm/25-50mm/50-75mm/75-100mm/
100-125mm/125-150mm/150-175mm/175-200mm

Thread Pitch Gauge

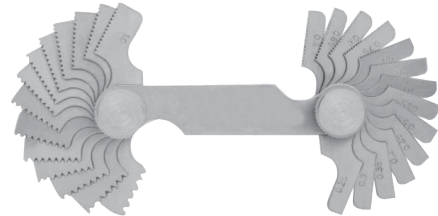

0.25-2.5mm/0.35-6mm/0.4-7mm

Micrometer Stand



Can Seam Micrometer



0-13mm

Rectangular Steel Gauge Block Sets



81PCS(Inch)/36PCS(Inch)/
122PCS/112PCS/103PCS/88PCS/76PCS/47PCS/18PCS

Telescoping Gauge



8-150mm

Interchangeable Anvil Outside Micrometer

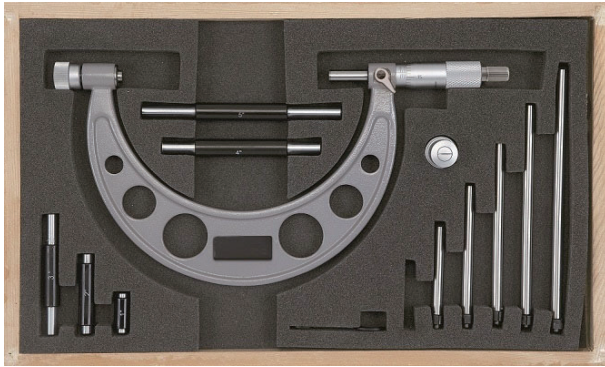

0-100mm/0-150mm/150-300mm/300-400mm/400-500mm/
500-600mm/600-700mm/700-800mm/800-900mm/900-1000mm

High-Precision Digital Height Gauge



0-50mm/0-100mm

Centering Indicators



0-3mm/0.15"

Dial Comparator



50-0-50

Sircumference Tapes



50-300mm/300-700mm/700-1100mm/
1500-1900mm/1900-2300mm/2300-2700mm/
2700-3100mm/3100-3500mm

Feeler Gage Tapes



0.02mm/0.03mm/0.04mm/0.05mm/0.06mm/0.07mm/
0.08mm/0.09mm/0.1mm/0.12mm/0.15mm/0.18mm/
0.2mm/0.25mm/0.3mm/0.35mm/0.45mm/0.5mm/
0.55mm/0.6mm/0.65mm/0.7mm/0.75mm/0.8mm/
0.85mm/0.9mm/0.95mm/1.0mm

Digital Protractor



Three Blades L:
150/200/300mm

Dial Snap Micrometer

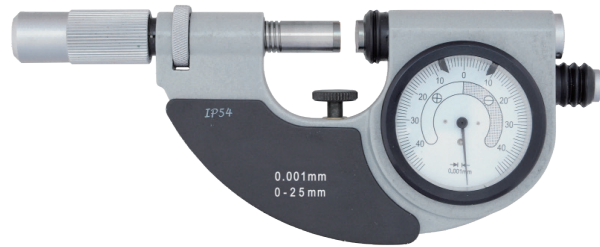

0-25mm/25-50mm/50-75mm/75-100mm

Universal Micrometers



0-25mm/25-50mm/
50-75mm/75-100mm

7 Pairs of Interchangeable Anvils



Surface Roughness Tester

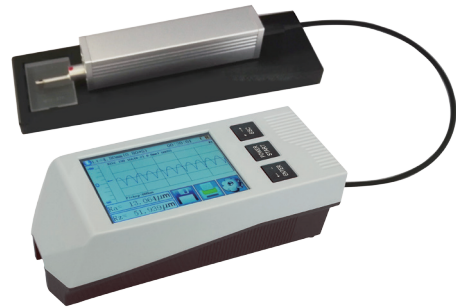

www.termatools.com

ADD: No. 25, Dongke Road, Dongcheng District,
Dongguan City, Guangdong Province, China
TEL: 86 769 85382030 85382230
FAX: 86 769 85382070

